

## Specifications

**Conveyor Widths:**

18 in to 72 in

**Capacity:**

Up to 10,000 tons per hour

**Belt Speed:**

Up to 1,200 feet per minute

**Accuracy Guidelines:**

Single-two idler system: 0.5%-1% total error

Three-four idler system: <0.5% total error

**System Accuracy:**

Guidelines assume clean belt with automatic tensioning system. Accuracy guidelines are typical. System accuracy may vary depending on environmental influences.



*Note: Idler not included. Customer is responsible for mounting idler to weigh frame.*

## Applications

- Mining, quarries, bulk material blending, process control, utilities, truck/berge/rail loading and retrofit

## Part Number/Price

Part #	Description	Est. Belt Width	Capacity	Price
<b>Mild Steel Weigh Frames</b>				
94968	24 in weigh frame	18 in	500 lb	Consult
95208	30 in weigh frame	24 in	500 lb	Consult
95209	36 in weigh frame	30 in	500 lb	Consult
95210	42 in weigh frame	36 in	500 lb	Consult
95211	48 in weigh frame	42 in	500 lb	Consult
95212	54 in weigh frame	48 in	500 lb	Consult
96717	60 in weigh frame	54 in	1,000 lb	Consult
96718	66 in weigh frame	60 in	1,000 lb	Consult
96719	72 in weigh frame	66 in	1,000 lb	Consult
Consult	Light-capacity weigh frames			Consult
<b>Stainless Steel Weigh Frames</b>				
110839	24 in weigh frame	18 in	500 lb	Consult
105246	30 in weigh frame	24 in	500 lb	Consult
110841	36 in weigh frame	30 in	500 lb	Consult
110842	42 in weigh frame	36 in	500 lb	Consult
110843	48 in weigh frame	42 in	500 lb	Consult
110844	54 in weigh frame	48 in	500 lb	Consult
110845	60 in weigh frame	54 in	500 lb	Consult
110846	66 in weigh frame	60 in	500 lb	Consult
110847	72 in weigh frame	66 in	500 lb	Consult
Consult	Light-capacity weigh frames			Consult
<b>Weigh Frame Accessories</b>				
97413	Shim, plastic 1/16 in thick			Consult
97414	Shim, plastic 1/8 in thick			Consult
97415	Shim, plastic 1/4 in thick			Consult
97416	Kit, shim 50 each 1/16 in, 1/8 in and 1/4 in thick			Consult
69203	Primer, light gray touch-up			Consult
66953	Paint, red touch-up			Consult

Please complete the Belt Scale Application on page 179 to obtain a quote

# BCi

In-Motion Belt Scale System

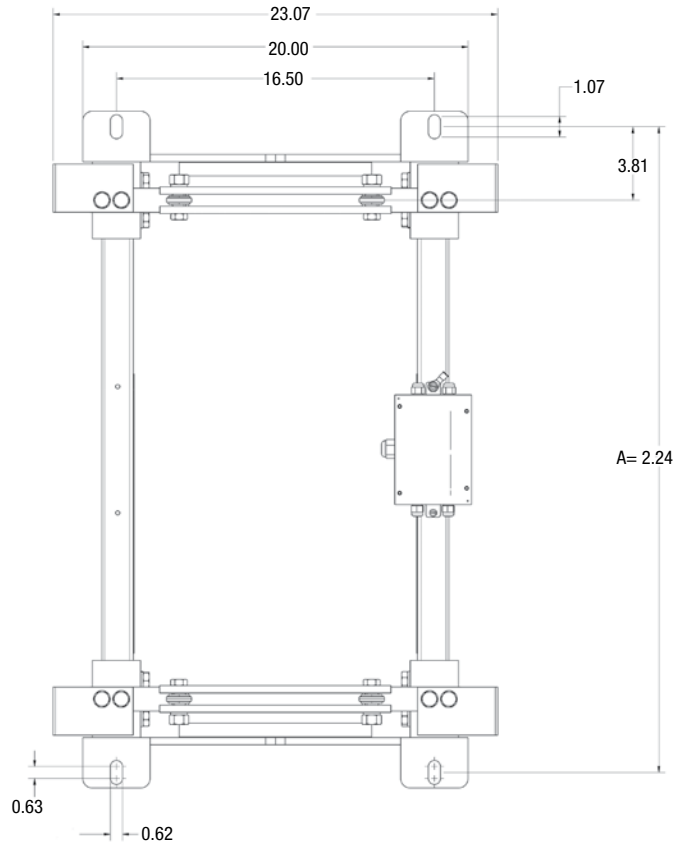
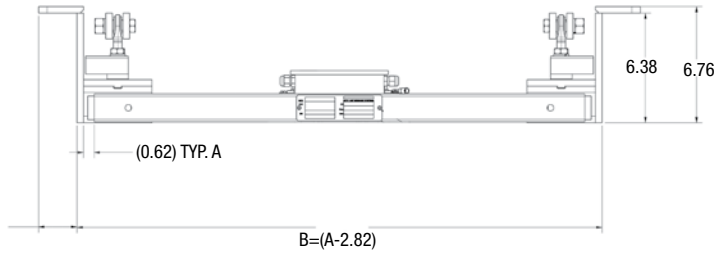

*Note: Cables on drawings removed for clarity. Idler mounting hardware is not included in weigh frame, see idler mounting bolts above.*