

MS200 and MS202

Portable and Permanent Monorail Scales



Standard Features

- 8 in long live rail designed to weigh one trolley at a time
- 750 lb x .5 lb resolution in both portable and permanent models
- Available for rail sizes 3/8 x 2 1/2 in or 1/2 x 2 1/2 in
- Requires less than 41 in of straight rail to install (14 in between rail hangers for permanent model)
- Zinc-plated, steel construction
- High accuracy, stainless steel load cell
- 25 ft of load cell cable for flexible installation
- Slightly recessed live rail for the trolley roller provides stable weighments

APPROVALS



Measurement
Canada
Approved

**MS202 only*

Part Number/Price

| Part # | Description | Weight | Price |
|--------|---|--------|---------|
| 19743* | MS200HB, NTEP Certified portable | 38 lb | Consult |
| 19744* | MS202HB-3/8 in, NTEP Certified permanent | 38 lb | Consult |
| 19745* | MS202HB-1/2 in, NTEP Certified permanent | 38 lb | Consult |
| 167585 | 25 ft 2 mv/v 350 ohm TH SST WS, NTEP 01-037 | 6 lb | Consult |

**Scale only, indicator not included*

Options/Accessories

| Part # | Description | Price |
|--------|-----------------------------|---------|
| 16984 | Additional operating manual | Consult |

NOTE: If scale is not going to be moved to different locations, the MS202 permanent model is recommended for easier transfer of the load.



The 52 in (1320.8 mm) section of rail supplied with the MS202 allows ample length for custom fitting to your specific area. This length is necessary when replacing a mechanical lever system.

The rail can be cut down to as short as 14 in (355.6 mm) for installation between two rail hangers. To make the weighing operation as simple as possible, the 8 in (203.2 mm) live-rail is mounted flush and level with the trolley rail.

MS202 Permanent Monorail Scale

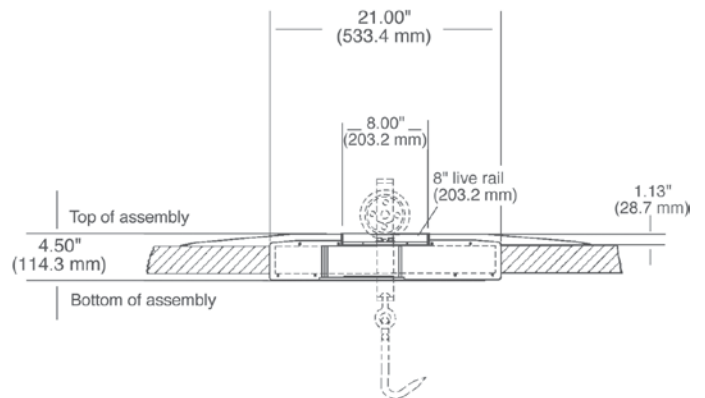

MS200/MS202 Dimensions

Specifications

MS200/MS202 Construction:

Zinc-plated steel construction, stainless steel hardware

Load Cell Construction:

Stainless steel

Bridge Resistance:

350 ohms nominal

Rated Output:

2 mV/V

Nonlinearity:

0.03% full scale

Approvals:

NTEP CC 90-003, Class III, nmax 1500
Measurement Canada *MS202 only