

C2P1

Alloy Steel, Environmentally Sealed, NTEP Certified 1:4,500 Class III Multiple Cell, IP67

VPG BLH



Dimensions

Picture is a representation of actual product

Rated Capacity lb/in	A	B	C	D	E	F	G	H	J	K	L
20,000-50,000	7.50	4.50	2.25	1.25	0.50	0.75	2.50	6.00	—	2.38	3/8-24 UNF x 3/8 DP
100,000	9.13	6.00	3.13	1.75	0.63	1.06	2.50	12.00	—	4.00	1/2-20 UNF x 3/4 DP
200,000	11.63	8.00	4.50	2.50	0.63	1.06	3.50	12.00	—	5.50	5/8-18 UNF x 1 DP
300,000	14.00	10.00	5.00	3.00	0.75	1.31	4.31	15.00	8.00	5.50	3/4-16 UNF x 1 1/4 DP
kg/mm											
9,071.9-22,679.6	190.5	114.3	57.2	31.8	12.7	19.1	63.5	152.4	—	60.3	3/8-24 UNF x 3/8 DP
45,359.2	231.8	152.4	79.4	44.5	15.9	27.0	63.5	304.8	—	101.6	1/2-20 UNF x 3/4 DP
90,718.5	295.3	203.2	114.3	63.5	15.9	27.0	88.9	304.8	—	139.7	5/8-18 UNF x 1 DP
136,078.1	295.3	203.2	114.3	63.5	19.1	27.0	109.5	304.8	203.2	139.7	3/4-16 UNF x 1 1/4 DP

Order Information

Load Rating		Part #	Est. Weight	Price
NTEP Certified, 10 ft Cables				
20,000 lb	9,071.9 kg	21625	25 lb	Consult
50,000 lb	22,679.6 kg	21626	25 lb	Consult
100,000 lb	45,359.2 kg	21627	50 lb	Consult
200,000 lb	90,718.5 kg	21628	110 lb	Consult
NTEP Certified, 35 ft Cables				
20,000 lb	9,071.9 kg	21630	25 lb	Consult
50,000 lb	22,679.6 kg	21632	25 lb	Consult
100,000 lb	45,359.2 kg	21633	50 lb	Consult
200,000 lb	90,718.5 kg	21634	110 lb	Consult
Non-NTEP Certified, 10 ft Cables				
300,000 lb	136,078.1 kg	17670	180 lb	Consult
Non-NTEP Certified, 35 ft Cables				
300,000 lb	136,078.1 kg	17671	190 lb	Consult

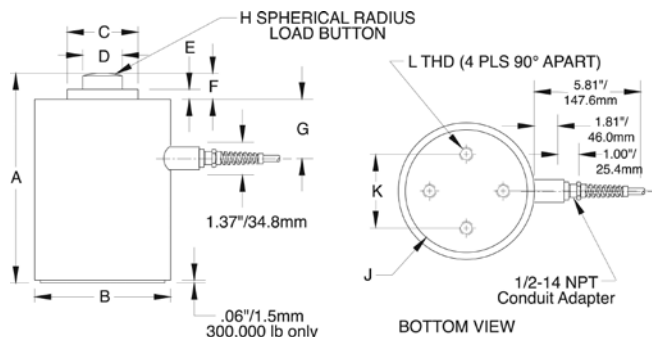

Interchangeable Products

HBM®	C10..... —
FAIRBANKS®	3-38065-X, 3-38066-X..... —
STREETER RICHARDSON®	2011611, 2011612..... —
STREETER RICHARDSON	2011613, 2011614, 2011617..... —
METTLER TOLEDO®	10049200A, 10014900A... —
METTLER TOLEDO	10011900A, 10049300A... —

Specifications

Full Scale Output:
2.0mV/V

Output Resistance:
350 (± 3.5) ohm

Input Resistance:
350 (± 3.5) ohm

Material/Finish:
High-alloy steel, epoxy coated

Temperature:
Compensated range
14°F to 104°F (-10°C to 40°C)
Operating range
-40°F to 150°F (-40°C to 65°C)

Seal Type:
NEMA Type 6 environmentally sealed, IP67

Safe Overload:
150% full scale

Rated Excitation:
5-10 VDC (20 V maximum)

Nonlinearity:
0.03% full scale

Hysteresis:
0.02% full scale

Insulation Resistance:
5,000 megohms

Deflection at Capacity:
20,000 lb-30,000 lb=0.0075 in (0.191 mm)
50,000 lb=0.0065 in (0.165 mm) 100,000 lb=0.0075 in (0.191 mm)
200,000 lb=0.0070 in (0.178 mm)
300,000 lb=0.012 in (0.305 mm)

Cable Length:
10 ft or 35 ft (3.0 m or 10.7 m)

Cable Color Code:
Green+ Excitation
Black.....- Excitation
White+ Signal
Red- Signal
Yellow- Shield

Warranty:
Three-year limited warranty

Approvals:



www.ricelake.com | Phone: 800-472-6703

