

Digital Baby Scale - Suspended Infant Scale

Specifications

Capacity:

OS-10: 22 lb x 0.02 lb (22 lb x 0.25 oz)
(10 kg x 0.01 kg)

OS-25: 55 lb x 0.05 lb (55 lb x 0.5 oz)
(25 kg x 0.02 kg)

OS-45: 99 lb x 0.1 lb (99 lb x 1 oz)
(45 kg x .05 kg)

Power:

Battery operated, two AA batteries included

Operating Temperature:

32° F to 104° F (6° C to 40° C)

Warranty:

One-year limited warranty



Sturdy steel
closed loop S-hook
for safety

Carrying case

Model OS-10/25/45

Standard Features

- Hold function
- Units of measure kg/lb/lb-oz
- Adjustable automatic shutoff
- Ergonomic handheld design
- Carrying case and top s-hook included

Part Number/Price

Part #	Model	Capacity	Price
130292	OS-10	22 lb x 0.02 lb (22 lb x 0.25 oz) (10 kg x 0.01 kg)	Consult
130293	OS-25	55 lb x 0.05 lb (22 lb x 0.5 oz) (25 kg x 0.02 kg)	Consult
130294	OS-45	99 lb x 0.1 lb (22 lb x 1 oz) (45 kg x 0.05 kg)	Consult

Shipping Weight

Part #	Model #	L (in)	W (in)	H (in)	Package Wgt. (lb)	Dim Wgt. (lb)	Shipping Wgt. (lb)
130292	OS-10	10	5	3	2	2	2
130293	OS-25	10	5	3	2	2	2
130294	OS-45	10	5	3	2	2	2

Options/Accessories

Part #	Description	Price
141444	Suspended pediatric sling seat trousers	Consult

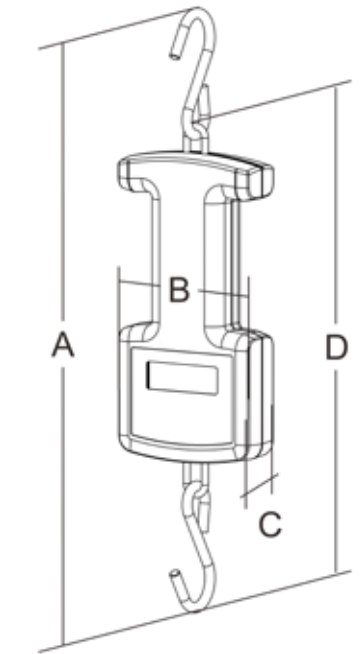

Dimensions

	Inches	Centimeters
A	14.27	36.25
B	3.62	9.2
C	1.26	3.2
D	11.56	29.35



Optional suspended pediatric sling trousers