

PW15AH

Stainless Steel, Hermetically Sealed, NTEP Certified 1:5,000 Class III Single Cell, IP69K



APPROVALS



Available upon request

Dimensions

Picture is a representation of actual product

Rated Capacity	B	E	F	G	H	I	J
kg/mm							
10-100	19.00	25.00	75.00	100.00	17.5	40.00	150.00
lb/in							
22-220.5	0.75	0.98	2.95	3.94	0.69	1.57	5.91

Order Information

Load Rating	Part#	Est. Weight	Price
10 kg	101915	3 lb	Consult
20 kg	101916	3 lb	Consult
50 kg	101917	3 lb	Consult
100 kg	101918	3 lb	Consult

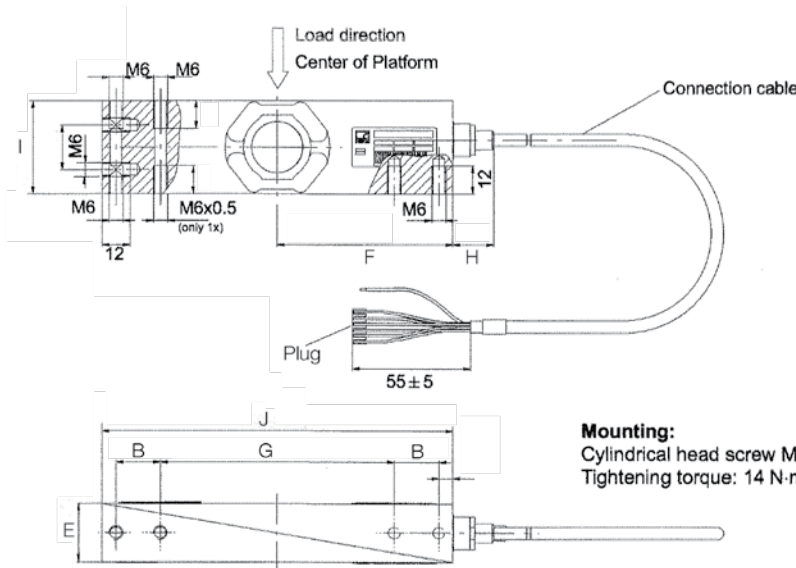

Interchangeable Products

RICE LAKE WEIGHING SYSTEMS
RLPWM15 page 178

Specifications

- Full Scale Output:**
2.0 mV/V
- Output Resistance:**
350 (± 10) ohms
- Input Resistance:**
380 (± 15) ohms
- Material/Finish:**
Stainless steel
- Temperature:**
Compensated range
14°F to 104°F (-10°C to 40°C)
Operating range
0°F to 150°F (-18°C to 65°C)
- Seal Type:**
Hermetically sealed, IP69K
- Safe Overload:**
150% full scale
- Rated Excitation:**
5- 10 VDC (15 V maximum)
- Combined Error:**
0.02% full scale
- Insulation Resistance:**
1,000 megohms
- Cable Length:**
10 ft (3.1 m)
- Cable Diameter:**
0.212 PVC jacket
- Cable Color Code:**
Blue +Excitation
Black -Excitation
White +Signal
Red -Signal
Green +Sense
Grey -Sense
- Warranty:**
One-year limited warranty
- Approvals:**
NTEP
OIML (Available upon request)