

106MHM1

Alloy Steel



Features:

- Assembles: 106MH-F Fatfoot® load cell
- Capacities: 500kg, 1t, 2t, 1Klb, 2.5Klb
- Center pivoted and Self-checking with 50% rated load anti-lifting protection
- All direction for thermal expansion and contraction

Load Cell Certifications:

CE RoHS

Load Cell Not Included.

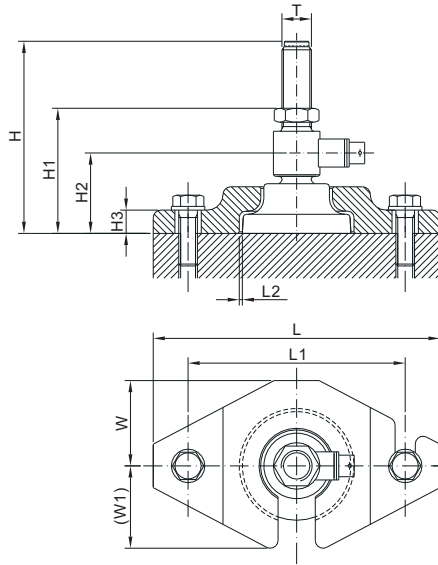

DIMENSIONS

LOAD CELL CAPACITY	H	H1	H2	H3	L	L1	L2	W	W1	T
Klb/inches										
1-2.5	3.75	2.67-3.58	1.72	0.55	6.89	5.51	0.08	1.97	1.95	1/2-20 UNF
t/mm										
0.5-1	95.3	68.0-91.0	43.8	14.0	175.0	140.0	2.0	50.0	49.5	M12
2	111.8	70.0-108.0	43.8	14.0	175.0	140.0	2.0	50.0	49.5	M16

PART NUMBER

Load Cell Capacity	Part No.	Weight (kg) Approx.
1Klb-2.5Klb	106MHM1-(1-2.5)Klb	1.38
0.5t-1t.....	106MHM1-(0.5-1)t	1.38
2t	106MHM1-2t	-